

Standard pumps

Centrifugal pumps CP08 and CP08 Pack alarm allow the condensate evacuation of air conditioning units up to 20 kW / 68 000 Btu.

They match with the standard cassettes of the market.

- 50 l/h - <26 dBA - IP54



Supplied with alarm sensor

Voltage ± 10 %	Frequency	Power	Operating cycle	Temperature rise	Protection	Dimensions	Discharge tube	Discharge head	Flowrate	Noise level
230V	50/60 Hz	8W	100 %	66 K	IP 54	82,5x76x97,3 mm	Ø14 mm	300 mm 1000 mm	50 l/h 20 l/h	<26 dBA <39 dBA

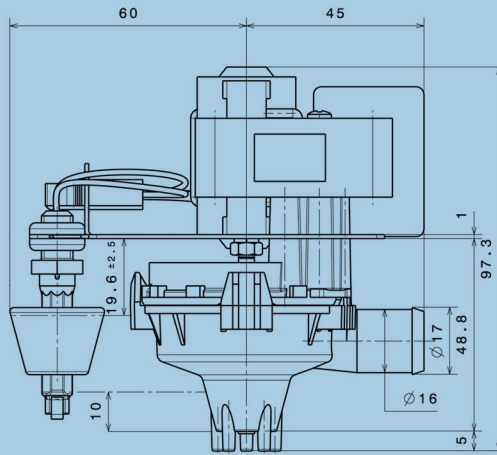
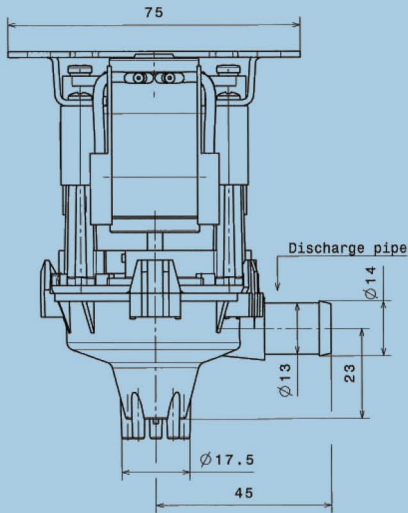

APPLICATIONS

Split cassettes and ductables
(air and water)
≤ 20 kW / 68 000 Btu



FLOWRATE

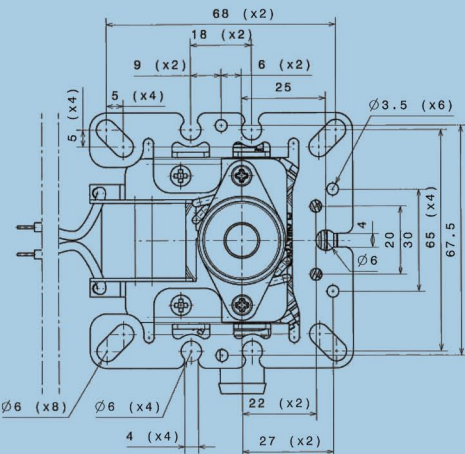
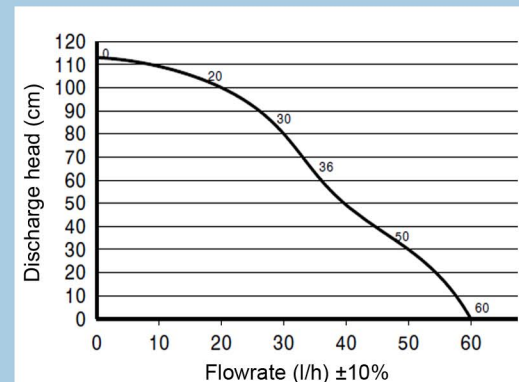

Drawing CP08SC6641

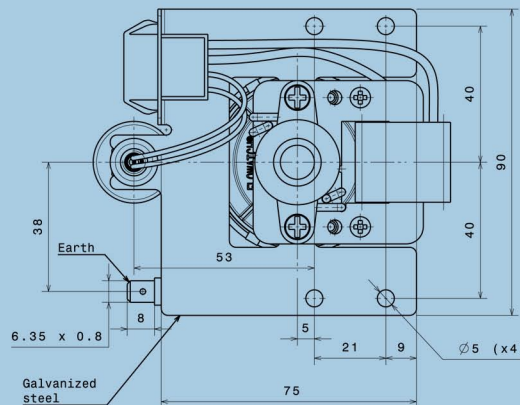

Drawing CP08 Pack alarm

Specific pumps OEM



SICCOM centrifugal pumps are designed and made on-demand for A/C manufacturers. They allow the condensate evacuation of air conditioning units up to 20 kW / 68 000 Btu.

SICCOM laboratory is at your disposal to propose you an efficient answer to your specifications.

Today SICCOM is supplier of great worldwide cassette manufacturers.

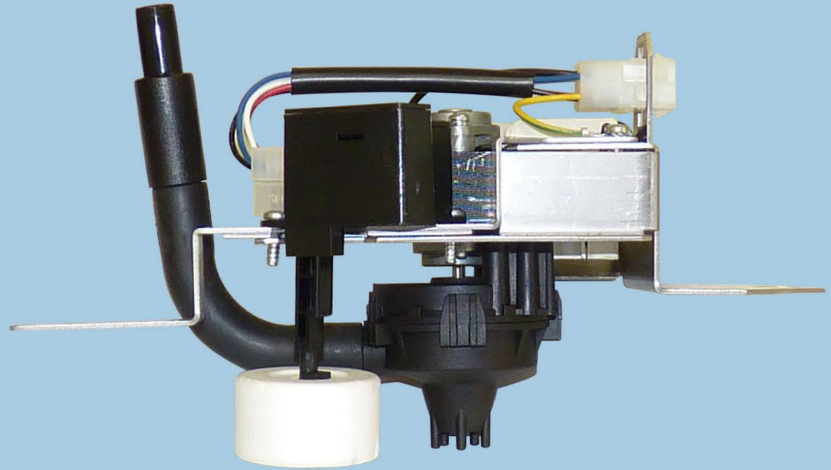

APPLICATIONS

Split cassettes and ductables
(air and water)
≤ 20 kW / 68 000 Btu

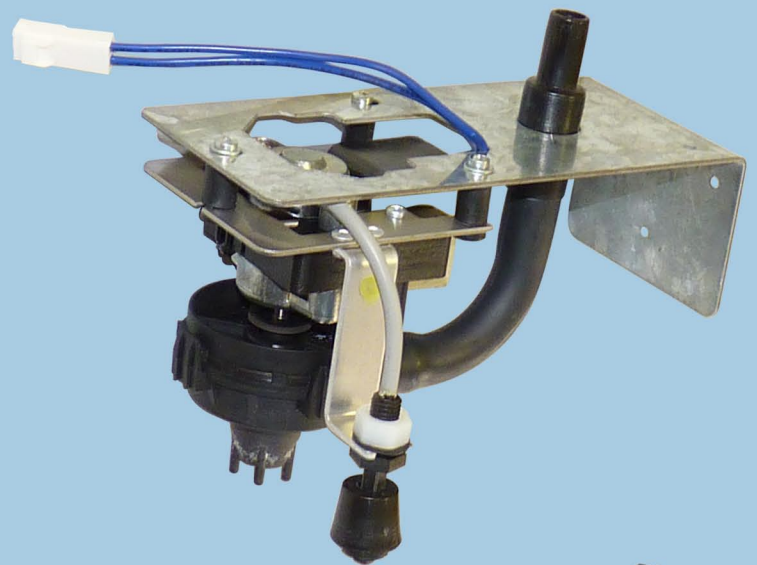

DESIGN ON-DEMAND

SICCOM can make on-demand pump set composed by:



Detection module

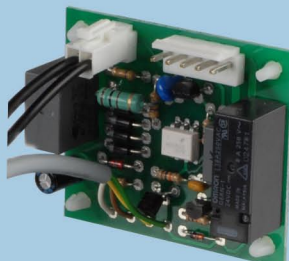

Electronic card



Plate



Centrifugal pump complete version